

# Loss Comparison of Selected Core Magnetic Materials Operating at Medium and High Frequencies and Different Excitation Voltages

Roderick Garcia<sup>1</sup>, Andrés Escobar-Mejía<sup>2</sup>, Kenny George<sup>3</sup>, Juan Carlos Balda<sup>4</sup>

Department of Electrical Engineering

University of Arkansas

Fayetteville, AR, USA

<sup>1</sup>rjgarcia@uark.edu, <sup>2</sup>axe011@uark.edu, <sup>3</sup>jkg001@uark.edu, <sup>4</sup>jbalda@uark.edu

**Abstract** — Availability of new high-power semiconductor devices and the desire for developing power systems with higher penetrations of distributed generation have sparked significant research in power electronic converters. The non-sinusoidal nature of the current and voltage waveforms commonly present in power electronic converters makes it difficult to accurately evaluate the copper and core losses of components such as inductors and transformers operating at high and medium frequencies. The evaluation of the core losses for three soft magnetic materials (amorphous, ferrite and nanocrystalline) under different rectangular-voltage waveforms used in solid-state transformers, duty cycles and switching frequencies is the main aim of this work. The test setup comprises a 10 kVA Si IGBT-based three-level full-bridge converter used to generate the rectangular-voltage waveforms exciting the cores. The comparison based on the main material properties establishes criteria for proper core material selection when designing high- and medium-frequency transformers.

**Keywords**—Core loss, nonsinusoidal waveform, soft-magnetic material.

## I. INTRODUCTION

The solid-state transformer (SST), also called power electronic transformer (PET), is proposed as a replacement to the conventional 50/60 Hz transformer used in many applications, especially in those that demand volume and weight reduction [1], [2]. The two key SST components are the power semiconductors and the high- or medium-frequency transformers (HF- or MF-XFMR). As a result of the power semiconductor's switching, the voltage applied across the primary of the transformer (and induced across the secondary winding) has rectangular shape with either two or three voltage levels [3]. Soft magnetic materials such as amorphous, ferrite and nanocrystalline are generally used as the transformer's core material for high- and medium-frequency applications due to advantages like low core losses when compared with hard magnetic materials such as silicon steel, which is preferred at frequencies below 1 kHz at any power rating [4].

For high-frequency and low-power applications, ferrite has become widely accepted as the core material of choice because it is commercially available in many shapes and sizes, and has low prices per unit of volume. However, materials such as

amorphous and nanocrystalline [5], [6] for high-power applications are considered better options due to their better properties when compared to ferrite materials [7]. Properties like high-saturation flux density, high permeability, high Curie temperature and low loss density make these materials convenient for high-density high-power applications [6].

A core-loss density comparison between a selected analytical method and experimental tests for three different core materials under rectangular-waveform excitation with variable duty cycle and variable switching frequency ( $f_{sw}$ ) is performed in this work. To this end, this paper is organized as follows: A summary of conventional methods used to calculate the core losses is given in section II, the test setup is described in section III, the comparison between the method selected to calculate the losses and experimental measurements is presented in section IV, considerations for core material selection are discussed in section V, and conclusions and recommendations for future work are addressed in section VI.

## II. THEORETICAL BACKGROUND

Typically, the time-average power loss per unit of volume in a transformer  $P_v$  is calculated by using the well-known Steinmetz equation (SE) [1]:

$$P_v = kf^\alpha B_m^\beta, \quad (1)$$

where  $k$ ,  $\alpha$  and  $\beta$  are constants related to the core material and typically determined by curve fitting the material loss curve provided by the manufacturer;  $B_m$  is the maximum (peak) induction flux density generated by a voltage waveform of frequency  $f$  (i.e.,  $f_{sw}$ ). Equation (1) is valid when the applied (excitation) voltage waveform is purely sinusoidal [8]–[10]. In the case of the SST and many other converters, rectangular waveforms with different voltage levels are usually applied to the HF- or MF-XFMR. For more-accurate calculations, methods like the modified Steinmetz expression (MSE) [8], the generalized Steinmetz equation (GSE) [9], and the improved generalized Steinmetz equation (iGSE) [10] must be used to predict the core losses when factoring in non-sinusoidal excitations. The relevant equations for the above methods are the following:

$$P_v|_{\text{MSE}} = (k f_{eq}^{\alpha-1} B_{max}^\beta) f_r, \quad (2)$$

$$f_{eq} = \frac{2}{\Delta B^2 \pi^2} \int_0^T \left( \frac{dB}{dt} \right)^2 dt$$

$$P_v|_{\text{GSE}} = \frac{1}{T} \int_0^T k_1 \left| \frac{dB(t)}{dt} \right|^\alpha |B(t)|^{\beta-\alpha} dt, \quad (3)$$

$$k_1 = \frac{k}{(2\pi)^{\alpha-1} \int_0^{2\pi} |\cos \theta|^\alpha |\sin \theta|^{\beta-\alpha} d\theta}$$

$$P_v|_{\text{iGSE}} = \frac{1}{T} \int_0^T k_1 \left| \frac{dB(t)}{dt} \right|^\alpha |\Delta B|^{\beta-\alpha} dt. \quad (4)$$

The GSE (3) is proposed as an improved version of the MSE (2) with reported errors within 5% and 40% [9]. The calculation of loss density with the GSE is based on the rate of change of the flux density and its instantaneous value  $B(t)$ ; however, inaccuracies are encountered in the presence of minor hysteresis loops since only instantaneous values are being considered [10]. Therefore, the instantaneous values are replaced by peak-to-peak values of the flux density  $\Delta B$  in the iGSE (4) overcoming the inaccuracies of the GSE [10].

For the methods mentioned above, the core losses would be zero during constant flux state (i.e., excitation voltage equals to zero). However, [11] demonstrated that even during these conditions, core losses still occur due to the “relaxation process” of the core material; thus even (4) does not contemplate the zero-voltage conditions commonly found in SSTs, losing accuracy for calculating core losses. Reference [11] proposed the so-called improved-iGSE (i<sup>2</sup>GSE) to overcome those inaccuracies in previous methods. However, the iGSE is still widely used because it is an improved version of the GSE, can be applied to arbitrary flux waveforms, and uses the same Steinmetz parameters as in (1) [10]–[11].

The peak flux density considering the excitation voltage waveform shown in Fig. 1(a) can be calculated as follows 0:

$$B = \frac{1}{2} \frac{V_{dc}}{N A_e} \frac{DT}{2} \quad (5)$$

where  $A_e$  is the effective core cross-sectional area,  $N = N_p = N_s$  is the number of winding turns ( $N_p$  primary winding turns and  $N_s$  secondary winding turns), and  $D$  is the duty cycle of the voltage waveform.

For the same three-level voltage profile of Fig. 1(a), the rate of change of the flux density can be calculated according to (6).

Then, the core losses per unit volume can be calculated following a piecewise linear model (PWL) using (4).

$$\frac{dB(t)}{dt} = \begin{cases} \frac{V_{dc}}{N A_e}, & 0 \leq t \leq D \frac{T}{2} \\ 0, & D \frac{T}{2} \leq t \leq \frac{T}{2} \\ -\frac{V_{dc}}{N A_e}, & \frac{T}{2} \leq t \leq (1+D) \frac{T}{2} \\ 0, & (1+D) \frac{T}{2} \leq t \leq T \end{cases} \quad (6)$$

### III. TEST BENCH SETUP TO MEASURE CORE LOSSES

In order to compare and evaluate the selected method (iGSE) for calculating the core losses with the results from experimental measurements, a three-level full-bridge converter, whose schematic is illustrated in Fig. 1(b), is prototyped as shown in Fig. 1(c) to generate the excitation voltage waveform illustrated in Fig. 1(a) at variable frequencies  $f_{sw}$  of 10, 20, 50, and 100 kHz, and duty cycles  $D$  of 12.5, 25, 37.5, and 50%. The peak flux density is kept constant at 0.1 T by adjusting the excitation voltage which can be solved from (5). The main properties of the three tested materials: amorphous Metglas 2605SA1 (AMCC-80) [12], ferrite 3C94 [13], and nanocrystalline Vitroperm 500F (W630) [14], are listed in Table I.

Several core loss measurement methods are discussed in [15]. With the so-called two-winding method, the averaged core loss power  $P$  over one switching period  $T$  can be obtained by measuring/sensing the voltage across the open secondary winding (sensing winding),  $v_s$ , reflected to the primary winding using the turns ratio, and the excitation current through the primary winding (excitation winding)  $i_p$ , [16]. Then,  $P$  is given by [17]:

$$P = \frac{1}{T} \int_0^T \frac{N_p}{N_s} v_s(t) \cdot i_p(t) dt \quad (7)$$

The main advantage of the two-winding method is that the copper losses are excluded from the measurements. The voltage drop across the leakage inductance and resistance of the primary winding are not measured since the voltage is sensed at the secondary side as shown in Fig. 1(b). However, the effects of phase discrepancy limit the use of this method to frequencies below 1 MHz [15]. A method that reduces the error due to phase discrepancy at higher frequencies by capacitive cancellation is proposed in [15].

The instruments used are Tektronix TCP202A current probes and P5200A differential voltage probes connected to a Tektronix TDS 3034B oscilloscope. The transformer core losses are also measured indirectly using a Hioki 3193 Power HiTESTER. In order to diminish the influence of the error in the current and voltage phase displacement measurements, the compensation method suggested in [16] is followed.

#### IV. EXPERIMENTAL RESULTS

The comparison between the core losses for the amorphous, ferrite, and nanocrystalline materials as a function of the duty cycle for different frequencies using the iGSE [10] and experimental data from the measurement approach described in section III is presented in Figs. 2, 3, and 4, respectively. Results in figures (a) are for 10 kHz, in figures (b) for 20 kHz, in figures (c) for 50 kHz and in figures (d) for 100 kHz. The authors in [11] proposed an improved method which considers the relaxation process of the magnetic material. Their results showed that the iGSE has more inaccuracies at lower duty cycles (with longer time intervals where the excitation voltage equals to zero) which agrees with the analysis presented in [11]. However, the duty cycle for the considered SST application will be modulated around 50%; so the iGSE method was selected since the authors demonstrated in [10] that their proposed method yields the most accurate results for the SST potential duty cycles.

For the three materials the losses decrease by increasing the duty cycles closer to 50%. It can be noticed from Fig. 5 that the material with lower losses is the nanocrystalline, followed by the ferrite and finally the amorphous. At  $D=50\%$  and  $f=100$  kHz the nanocrystalline material (Vitroperm 500F) has approximately 8 times lower losses than the ferrite (3C94), and the latter has approximately 1.5 times lower losses than the amorphous (Metglas 2605SA1). Ferrite cores with lower losses are commercially available. In [18] a comparison between nanocrystalline Vitroperm 500F and ferrite N87 is presented. In this case the ferrite core shows 2.5 more losses than the nanocrystalline.

#### V. CONSIDERATIONS FOR CORE MATERIAL SELECTION

The core material selection is a critical aspect in a transformer design [20], especially in high-frequency transformers because, as shown in Fig. 5, increasing the operating frequency has a considerable impact in the transformer efficiency and thermal management requirements. In order to properly select the core material four main material parameters, given in Table I, could be considered: core loss density, saturation flux density, permeability, and Curie temperature [6]. The experimental results show that the ferrite core present lower losses than the amorphous core; however, its low saturation flux density results in larger core sizes, thus it is not well suitable in applications where reduced size and volume are desired. In addition, they have the lowest Curie temperature among the selected materials, another limitation in high-power applications. The amorphous core has the highest loss per unit volume. However, it has high Curie temperature, high permeability and high saturation flux density, which leads to high-power density in high-power applications. The nanocrystalline core has the lowest loss density compared to ferrite and amorphous; in addition it has high saturation flux density. These characteristics promise high efficiencies and high power densities. Moreover, this material has the highest Curie temperature among the selected materials, which allows operation at high temperatures. However, if the transformer design is based on cost, the amorphous core would be the best option since the cost of the nanocrystalline core is relatively high [6].

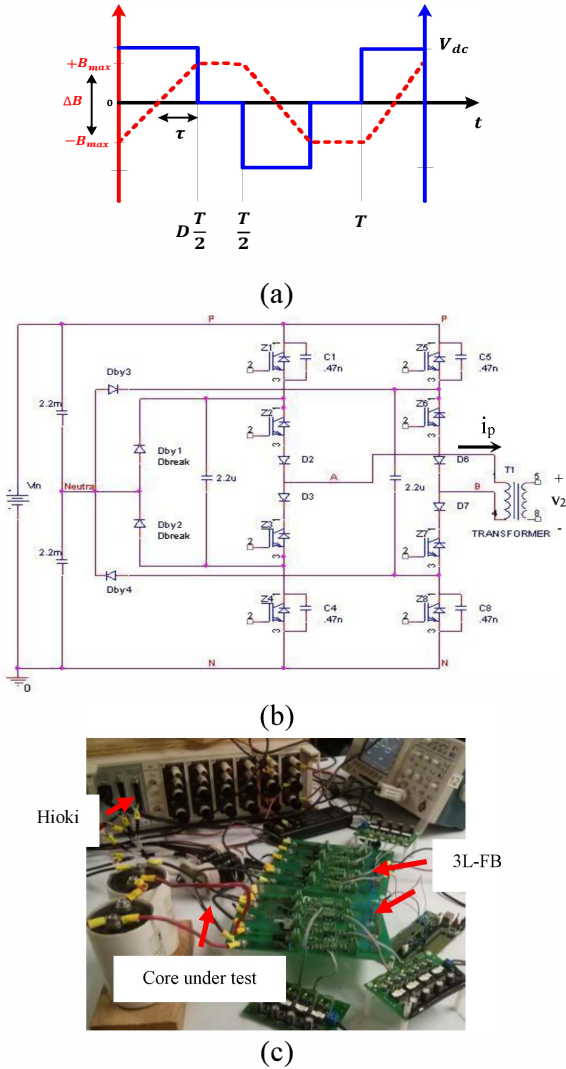
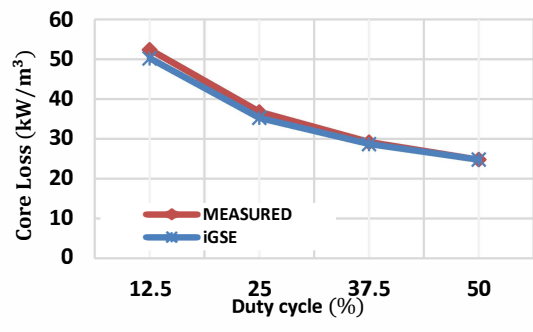

Fig. 1. Three-level full-bridge converter (3L-FB): (a) excitation waveform, (b) schematic, and (c) prototype

Table I. SOFT-MAGNETIC MATERIALS MAIN PROPERTIES

Parameter	Amorphous	Ferrite 3C94	Nanocrystalline Vitroperm 500F W630
	Metglas 2605SA1 AMCC-80		
$B_{sat}$ (T)	1.56	0.47	1.2
Curie Temp ( $^{\circ}$ C)	399	220	600
Permeability, $\mu_i$ ( $\times 10^3$ )	10-150	2.3	15
$K$	1.3617	17.1	2.3
$\alpha$	1.51	1.46	1.32
$\beta$	1.74	2.75	2.12
$A_e$ ( $cm^2$ )	5.20	2.80	2.74
$l_m$ (cm)	25.4	12.7	36.1



(a)

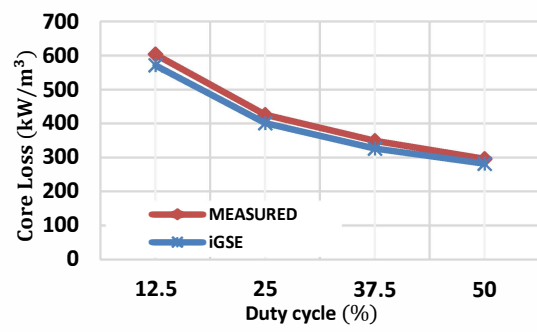

(c)

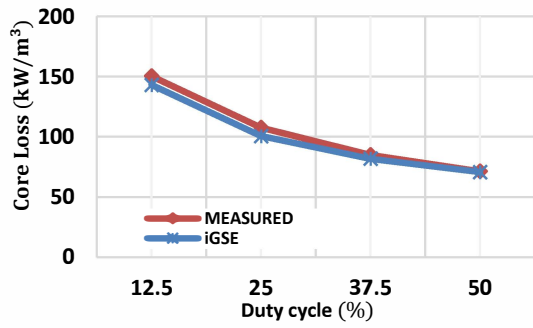

(b)

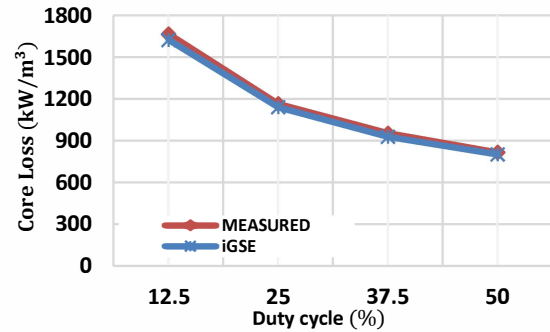

(d)

Fig. 2. Amorphous core losses for  $f = 10$  kHz (a),  $f = 20$  kHz (b),  $f = 50$  kHz (c) and  $f = 100$  kHz (d) at different duty cycles

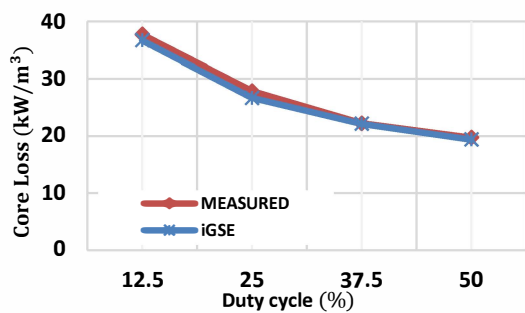

(a)

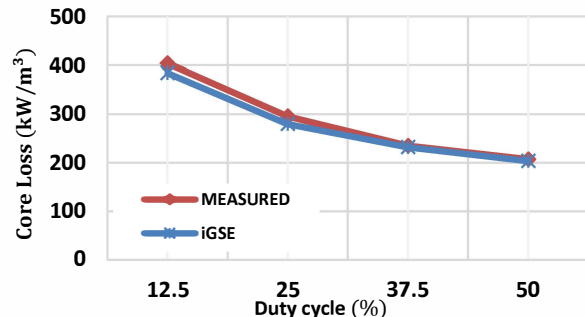

(c)

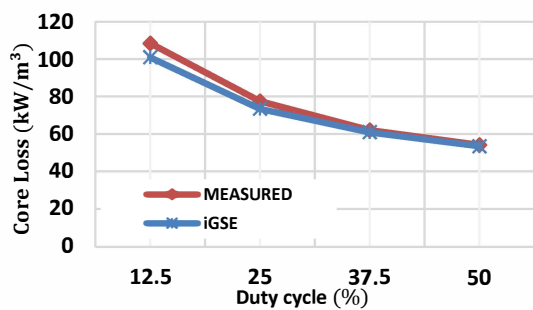

(b)

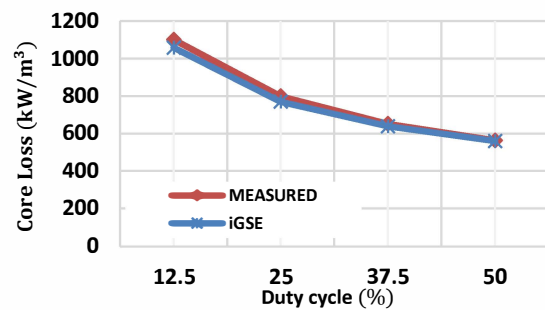

(d)

Fig. 3. Ferrite core losses for  $f = 10$  kHz (a),  $f = 20$  kHz (b),  $f = 50$  kHz (c) and  $f = 100$  kHz (d) at different duty cycles

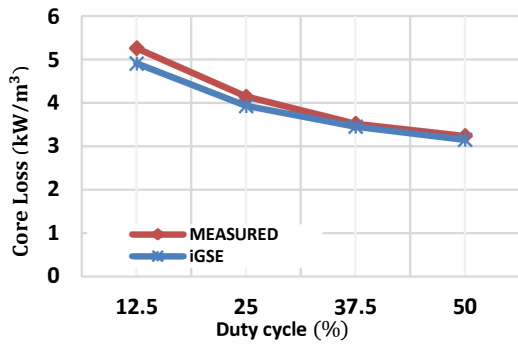

(a)

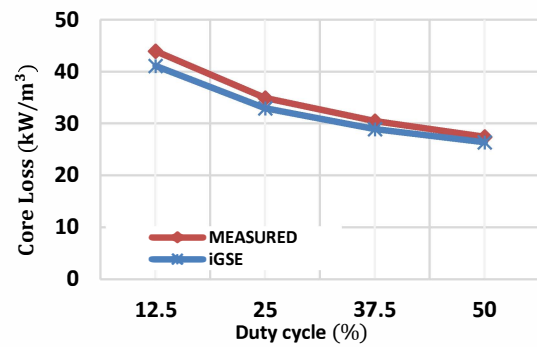

(c)

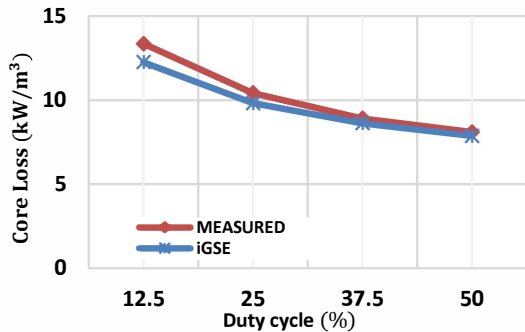

(b)

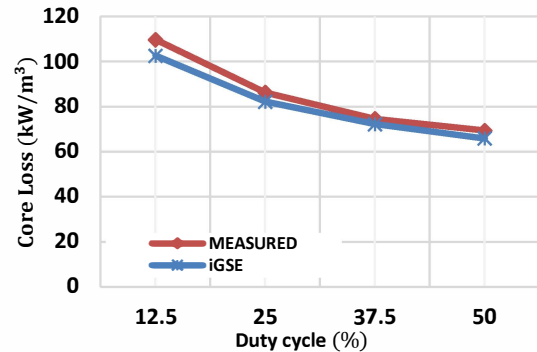

(d)

Fig. 4. Nanocrystalline core losses for  $f = 10$  kHz (a),  $f = 20$  kHz (b),  $f = 50$  kHz (c) and  $f = 100$  kHz (d) at different duty cycles

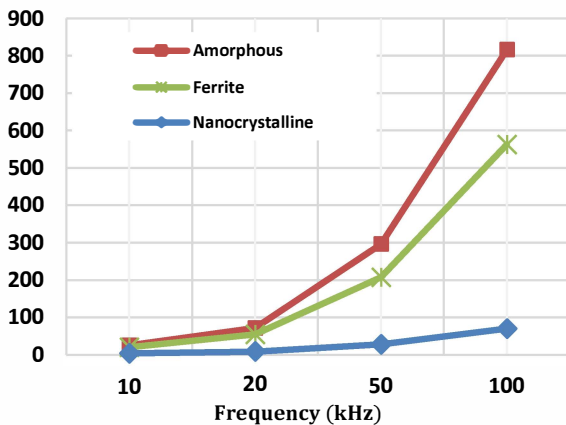

Fig. 5. Core losses for amorphous Metglas 2605SA1, ferrite 3C94, and nanocrystalline Vitroperm 500F W630 as a function of the frequency at  $D=50\%$ , 0.1 T peak

## VI. CONCLUSIONS AND FUTURE WORK

The comparison between the core losses of three soft magnetic materials commonly used for HF- or MF-XFMR under non-sinusoidal excitation conditions with variable frequencies and duty cycles was given in this paper. The iGSE was used to calculate the core losses and the results were

compared with the experimental results. As stated in [11] the iGSE shows more deviation from the experimental results at low duty cycles because of not considering the relaxation process in magnetic materials. The  $i^2$ GSE could be used to improve the accuracy of the calculations.

Transformer design considerations based on four main material parameters (core loss density, saturation flux density, Curie temperature, and permeability) were analyzed. The nanocrystalline core showed the lower losses among the other core materials, followed by the ferrite, and the amorphous. The amorphous and nanocrystalline materials have high saturation flux density, high permeability, and they can operate at higher temperatures, thus these materials are suitable for high-frequency high-power applications.

## ACKNOWLEDGMENTS

The authors are grateful for the financial support from the National Science Foundation Industry/University Cooperative Research Center on Grid-connected Advanced Power Electronics Systems (GRAPES). Mr. Roderick Garcia is grateful for the financial support from the Fulbright-SENACYT program. Mr. Andrés Escobar-Mejía is grateful for the financial support as assistant professor of the Universidad Tecnológica de Pereira (Colombia) through the studies commission grant for full-time professors and the Fulbright-LASPAU program.

## REFERENCES

- [1] R.A. Friedemann, F. Krismer, J.W. Kolar, "Design of a minimum weight dual active bridge converter for an airborne wind turbine system," in *Proc. of the 27th Annual IEEE Applied Power Electronics Conference and Exposition*, APEC 2012, pp. 509–516, February, 2012.
- [2] D. Dujic, F. Kieferndorf, F. Canales, U. Drogenik, "Power electronic traction transformer technology," in *Proc. of the 7th IEEE International Power Electronics and Motion Control Conference*, IPEMC 2012, pp. 636–642, June, 2012.
- [3] B. Reese, M. Schupbach, A. Lostetter, B. Rowden, R. Saunders, J.C. Balda, "High voltage, high power density bi-directional multi-level converters utilizing silicon and silicon carbide (SiC) switches," in *Proc. of the 23rd Annual IEEE Applied Power Electronics Conference and Exposition*, APEC 2008, pp. 252–258, February, 2008.
- [4] X. She, R. Burgos, G. Wang, F. Wang, A.Q. Huang, "Review of solid state transformer in the distribution system: From components to field application," in *Proc. of the IEEE Energy Conv. Cong. and Exp.*, ECCE 2012, pp. 4077–4084, Sept., 2012.
- [5] G. Ortiz, M. Leibl, J.W. Kolar, O. Apeldoorn, "Medium frequency transformers for solid-state-transformer applications — Design and experimental verification," in *Proc. of the 10th IEEE International Conference on Power Electronics and Drive Systems*, PEDS 2013, pp. 1285–1290, April, 2013.
- [6] X. She, R. Burgos, G. Wang, F. Wang, A.Q. Huang, "Review of solid state transformer in the distribution system: from components to field application," in *Proc. of the Energy Conv. Cong. and Exp.*, ECCE 2012, pp. 4077–4084, Sept., 2012.
- [7] Y. Wang, S.W.H. De Haan, J.A. Ferreira, "Design of low-profile nanocrystalline transformer in high-current phase-shifted DC-DC converter," in *Proc. of the IEEE Energy Conversion Congress and Exp.*, ECCE 2010, pp. 2177–2181, September, 2010.
- [8] J. Reinert, A. Brockmeyer, R.W. De Doncker, "Calculation of losses in ferro- and ferrimagnetic materials based on the modified Steinmetz equation," *IEEE Trans. on Industry Applications*, vol. 37, no. 4, July/August, 2001.
- [9] J. Li, T. Abdallah, C.R. Sullivan, "Improved calculation of core loss with nonsinusoidal waveforms," in *Proc. of the IEEE Industry Applications Society Annual Meeting*, pp. 2203–2210, October, 2001.
- [10] K. Venkatchalam, C.R. Sullivan, T. Abdallah, H. Tacca, "Accurate prediction of ferrite core loss with nonsinusoidal waveforms using only Steinmetz parameters," in *Proc. of the 8th IEEE Workshop on Computers in Power Electronics*, COMPEL 2002, pp.1–6, June, 2002.
- I. Villar, U. Viscarret, I. Etxeberria-Otadui, A. Rufer, "Global loss evaluation methods for Nonsinusoidally Fed medium-frequency power transformers," *IEEE Trans. on Industrial Electronics*, vol. 56, no. 10, pp. 4132–4140, October, 2009.
- [11] J. Mühlethaler, J. Biela, J.W. Kolar, A. Ecklebe, "Improved core-loss calculation for magnetic components employed in power electronic systems," *IEEE Trans. on Power Electronics*, vol. 27, no. 2, pp. 964–973, February, 2012.
- [12] Metglas®, "Powerlite® inductor cores technical bulletin," [Online]. Available: <http://www.elnamagnetics.com/wp-content/uploads/catalogs/Metglas/powerlite.pdf>
- [13] Ferroxcube, "Soft ferrites and accessories data handbook 2013," [Online]. Available: [http://www.ferroxcube.com/FerroxcubeCorporateReception/datasheet/FXC\\_HB2013.pdf](http://www.ferroxcube.com/FerroxcubeCorporateReception/datasheet/FXC_HB2013.pdf)
- [14] Vacuumschmelze, "nanocrystalline cut cores made of VITROPERM 500F for transformers," [Online]. Available: <http://www.vacuumschmelze.com/index.php?id=1166>
- [15] M. Mu, Q. Li, "New core loss measurement method for high-frequency magnetic materials," *IEEE Trans. on Power Electronics*, vol. 29, no. 8, August 2014.
- [16] J. Mühlethaler, J. Biela, J.W. Kolar, A. Ecklebe, "Core losses under the DC bias condition based on Steinmetz parameters," *IEEE Trans. on Power Electronics*, vol. 27, no. 2, pp. 953–963, February, 2012.
- [17] Y. Han, Y. Liu, "A practical transformer core loss measurement scheme for high-frequency power converter," *IEEE Trans. on Industrial Electronics*, vol. 55, no. 2, February 2008.
- [18] V. Valchev, A. Van den Bossche, P. Sergeant, "Core loss in nanocrystalline soft magnetic materials under square voltage waveforms," *Journal of Magnetism and Magnetic Materials*, vol. 320, pp. 53-57, 2008.
- [19] W.G. Hurley, W. H. Wölfle, J. G. Breslin, "Optimized transformer design: Inclusive of high-frequency effects," *IEEE Trans. on Power Electronics*, vol. 13, no. 4, July 1998.